

BH Pneumatic Piston Vibrators

Operation, Maintenance, and Troubleshooting

MAINTENANCE:

1. Check automatic lubricator and fill with recommended oil type if level is low (see Bulletin 4000.503).
2. Check to see that air pressure is correctly set for most efficient operation. If filter is installed in system, drain to remove contaminants (water, scale, etc).
3. Check all air connections and tighten if necessary.
4. Torque an bolts that may have been loosened over a period of time (maintenance/plant-shutdown).
5. Be certain that vibrator is well lubricated at all times. One way to check this is to place hand over exhaust while running. A thin film of oil on the palm of the hand will confirm that the vibrator is being lubricated properly.

AIR CONTROL CONNECTION:

1. Install air control package (Figure 1)
2. Blow out air line to flush contaminants before connecting the vibrator
3. Fill the lubricator with recommended lubricant or oil (see Bulletin 4000.503)
4. Open valve
5. Set the pressure regulator to 50 PSI (see FRL instructions)
6. Adjust the lubricator to recommended setting (see Bulletin 4000.503)
7. Adjust air regulator to the lowest pressure that will give the desired material flow performance, NOT to exceed 60 PSI

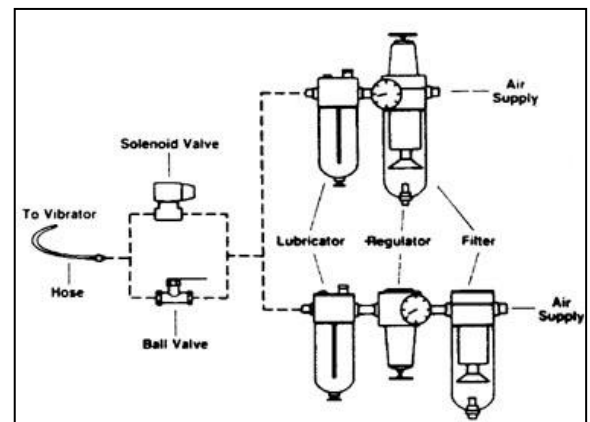

Figure 1

INSTALLATION NOTE: All vibrators must be installed with an inline lubricator, filter and regulator.

MOUNTING WITH T-SLOT MOUNTING PLATE

Note: Use t-slotted mounting plate (See Figure 2). Safety cable recommended.

1. Determine proper mounting location. Assure a mounting angle greater than 20 degrees, unless 'SP' type.
2. Skip weld reinforcing plate to hopper. Do not weld corners. NAVCO can recommend weld specifications if required.
3. Skip weld t-slot to reinforcing plate. Do not weld corners. NAVCO can recommend weld specifications if required.
4. Insert bolts in slots and position vibrator onto t-slot.
5. Install lock washer (if included) and nut. Torque mounting hardware to recommended specification.
6. Re-torque mounting hardware after 24 hours of equipment operation.

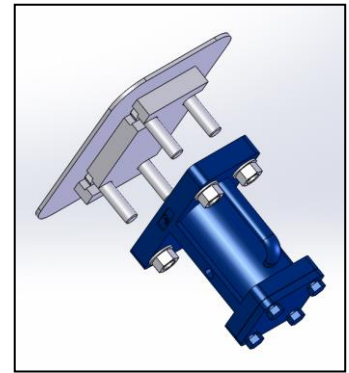

Figure 3

MOUNTING WITH CHANNEL MOUNTING

Note: Use channel mounting plate (See Figure 3). Safety cable recommended.

1. Determine proper mounting location. Assure a mounting angle greater than 20 degrees, unless 'SP' type.
2. Skip weld reinforcing bars to hopper. Do not weld corners. NAVCO can recommend weld specifications if required.
3. Skip weld both channel legs to reinforcing bars. Do not weld corners. NAVCO recommend exact weld specifications if required.
4. Install vibrator and mounting bolts.
5. Install lock washer (if included) and nut. Torque mounting hardware to recommended specification.
6. Re-torque mounting hardware after 24 hours of equipment operation.

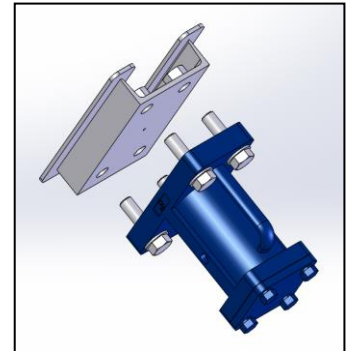

Figure 2

TROUBLE-SHOOTING:

1. Vibrator will not start:
 - a. Check to see that quick-opening valve is properly installed
 - b. Vibrator should be within 5 to 10 feet of operating valve
 - c. Be sure vibrator has adequate air pressure and volume available
2. Vibrator is sluggish and slow to start:
 - a. Check for adequate lubrication
 - b. Check for leaking airline or defective operating valve
 - c. Check air supply for pressure and volume
3. For other issues, consult the complete operation/maintenance manual or contact NAVCO directly

CONDITIONAL WARRANTY

All NAVCO vibrators are warranted for twelve (12) full months from the date of purchase. NAVCO will repair or replace any portion of the vibrator proven defective in quality or workmanship (see Bulletin 4000.508 for details).

The following conditions will determine warranty credit:

1. All vibrators must be installed with an inline lubricator, filter, and regulator
2. All vibrators must be properly installed according to instructions
3. All vibrators must be free of signs of abuse, misuse, or contamination of chamber by foreign material
4. Vibrators must NOT be disassembled by customer

To obtain credit, vibrators must be returned to NAVCO freight prepaid. NAVCO will prepay return freight on warranted vibrators. Non-warranted repairs will be returned collect. NAVCO will provide a list of repairs and an estimate of repair cost. Non-warranted repairs are made on acceptance of this cost.

For complete operation/maintenance manual, visit the BH product page online at www.navco.us