

Concrete Form Vibrators

Dimensions and
Specifications

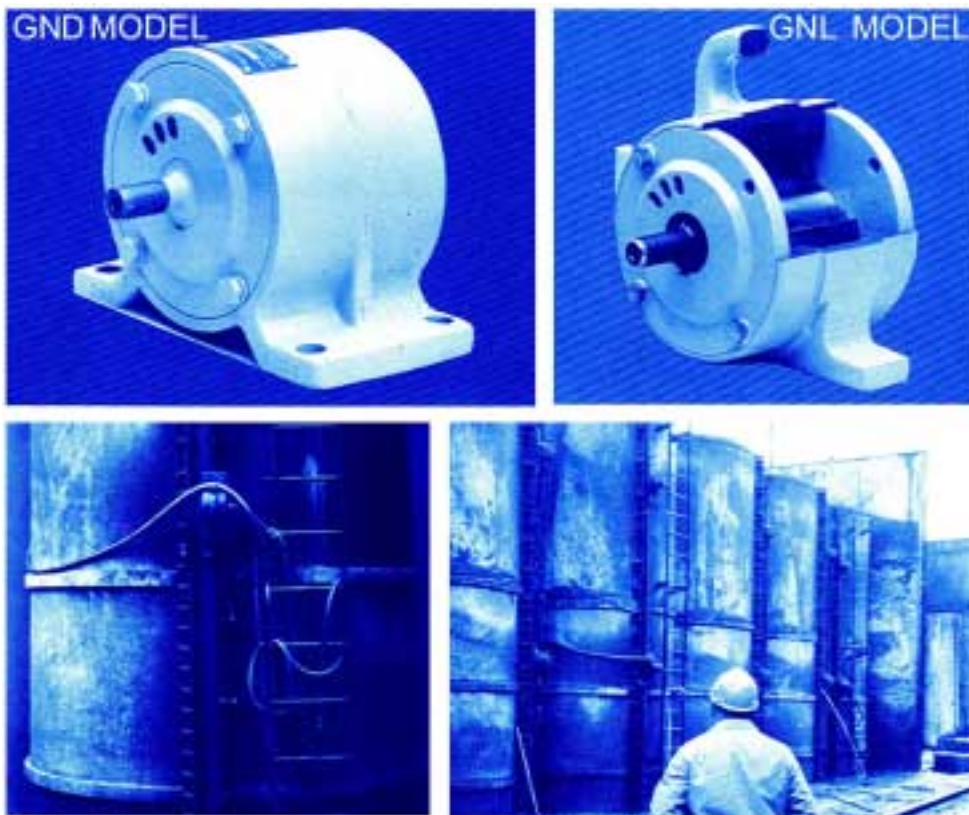

NAVCO high frequency concrete form vibrators provide an effective, economical solution to consolidating concrete.

SPECIFICATIONS

Vibrator Model	Weight	Unbalance Lb-in.	Start PSI	40 PSI			60 PSI			80 PSI		
				Speed RPM	Flow SCFM	Force Lb	Speed RPM	Flow SCFM	Force Lb	Speed RPM	Flow SCFM	Force Lb
GNL-4400	32.8	.60	12	9500	46	1750	12000	54	3000	15400	61	4850
GND-4400	34.8	.60	12	9500	46	1750	12000	54	3000	15400	61	4850
GNL-5000	33.2	.80	14	9350	47	2000	11800	57	3150	14500	63	5000
GND-5000	35.2	.80	14	9350	47	2000	11800	57	3150	14500	63	5000
GNL-5500	33.4	1.4	15	8800	48	3000	9000	59	3250	11500	64	5200
GND-5500	35.4	1.4	15	8800	48	3000	9000	59	3250	11500	64	5200
GNL-6500	36.8	2.8	20	7600	49	3200	8200	60	3650	10000	67	6600
GND-6500	38.7	2.8	20	7600	49	3200	8200	60	3650	10000	67	6600

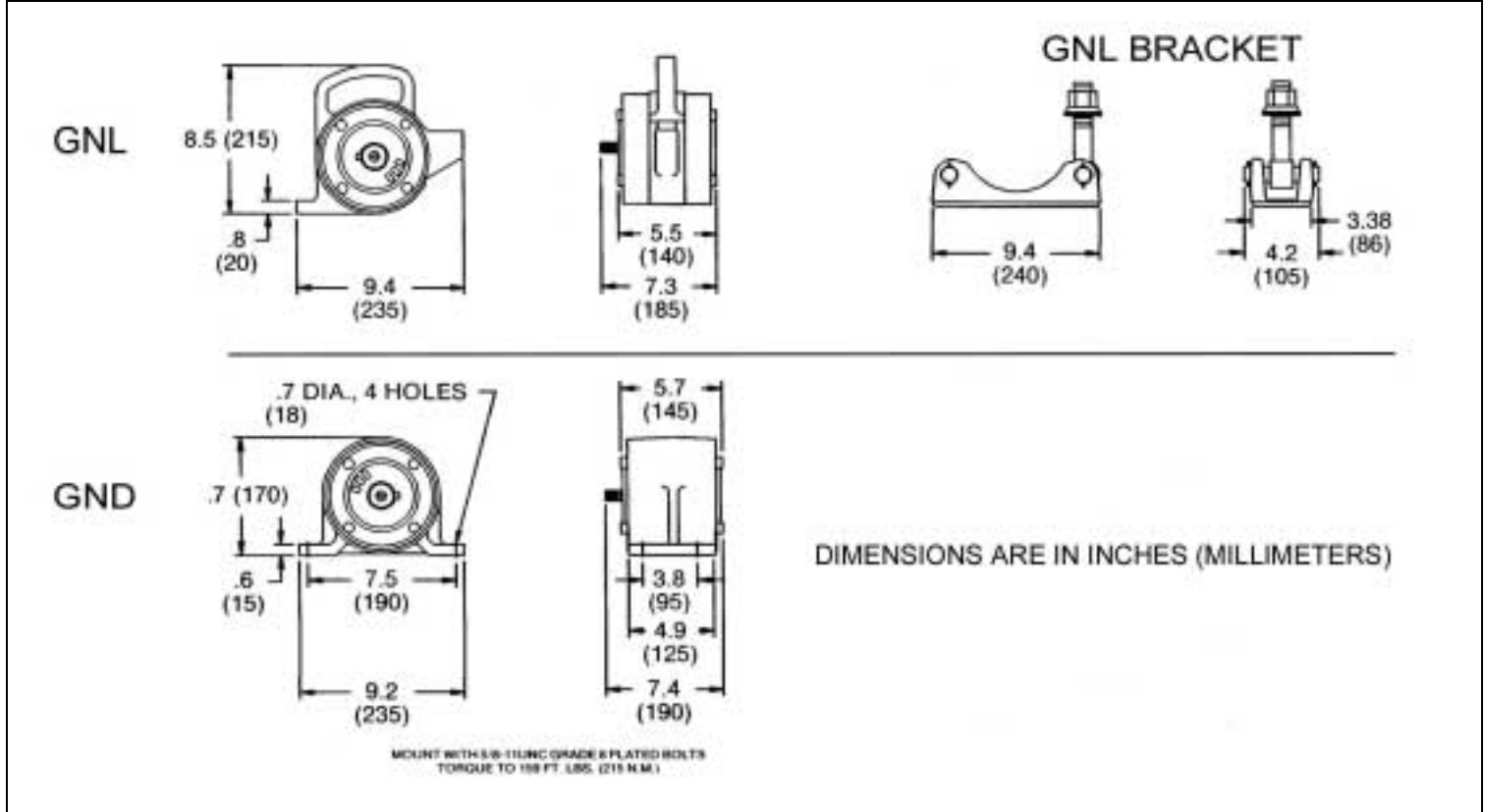

The NAVCO GNL model vibrator is used with a bracket for portability, making it easy to move to different forms. The GND vibrator has a bolt-on base for permanent mounting. A channel iron stiffener should always be used to distribute vibration evenly. Vibrators should be mounted vertically, with an upwards rotation to force air to the surface of the form.

NAVCO

P.O. Box 40563, Houston TX 77240-0563

Ph: (832) 467-3636 Fax: (832) 467-3800

TOLL FREE 1-800-231-0164

www.navco.org navcosales@navco-jvi.com

Represented By: