

FV Vice Mount Vibrator

Portable, Clamping Industrial Vibrator

The FV Vice Mount Vibrator from NAVCO is a uniquely engineered for form applications. Designed to aid settling in forms, these vibrators attach to the exterior of the form wall through an incorporated vice mount on the vibrator's head. This built in vise eliminates the need for special mounting brackets often required by other portable models.

Quality Vibrators Built in the USA

Made in the USA, the FV Vice Mount Vibrator is designed and built in Houston, TX. Since its inception it has been utilized across the US to promote settling in form applications.

Supporting Industry

Designed for form applications, the FV Vice Mount Vibrator has been utilized across many industries, including. Concrete, Steel, Construction, and more.

Pneumatic Piston Vibrator, Runs off Air

FV Vice Mount Vibrator is a pneumatic piston style vibrator that is runs off ofon compressed air. This allows the vibrator to be easily incorporated into any process with access to plant / instrument air.

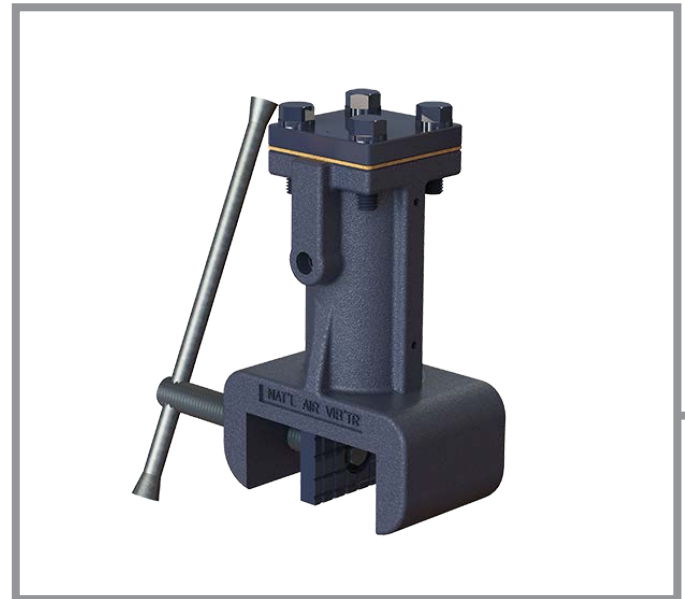

Form Vibrator with A Vise Mount

Effectively settles concrete to remove air and excess water. FV Vice Mount Vibrators fasten easily on wooden or steel forms and utilize vibration to force out air pockets, improve surface finish, and speed up mold release.

Improve Foundry Processes

The FV Vice Mount Vibrator gives fast, clean draws which helps extend core box life by eliminating distortion.

One-Piece Construction

The Vibrator utilizes features a one-piece construction design. The jaws of the clamp are incorporated into the housing eliminating the need for assembly bolts.

Easily Clamps to Most Structures

The FV Vice Mount Vibrators vise style clamp can be used on a wide variety of applications including wooden forms, steel forms, and core boxes where only periodic vibration is required.

Completely Portable Vibration

The vice mount allows the vibrator to easily be moved from form to form as vibration is need.

Controllable Vibration

Vibration frequency is easily controlled by adjusting the air supply pressure from 20 to 60 PSI.

CONTACT US TODAY AT

E. SALES@NAVCO.US

W. NAVCO.US

A. 11929 BRITTMOORE PARK DR.

P. 832.467.3636

F. 832.467.3800

HOUSTON, TX 77041

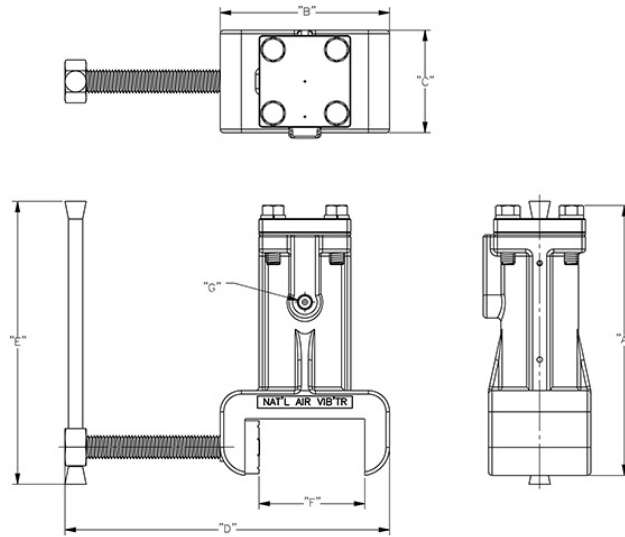

Model	A	B	C	D	E	F	G NPT	Weight (lbs)	Air Consumption (SCFM @ 50 PSI)
FV 2.00	9-9/16"	6"	9-5/8"	1-1/2"	10"	3-3/4"	1/4"	22	7.4



CONTACT US TODAY AT

E. SALES@NAVCO.US
P. 832.467.3636

W. NAVCO.US
F. 832.467.3800

A. 11929 BRITTMOORE PARK DR.
HOUSTON, TX 77041